

Product datasheet

Specifications



soft starter for asynchronous motor - ATSU01 - 22 A - 200..480 V - 4..11 KW

ATSU01N222LT

Price: 8,273.05 ZAR

Main

Range of product	Altistart U01 and TeSys U
Product destination	Asynchronous motors
Product or component type	Soft starter
Product specific application	Simple machine
Device short name	ATSU01
Network number of phases	3 phases
[Us] rated supply voltage	200...480 V - 10...10 %
Motor power kW	11 kW, 3 phases at 400 V 4 kW, 3 phases at 230 V 7.5 kW, 3 phases at 400 V 5.5 kW, 3 phases at 230 V
Motor power hp	5 hp, 3 phases at 230 V 7.5 hp, 3 phases at 230 V 10 hp, 3 phases at 460 V 15 hp, 3 phases at 460 V
IcL starter rating	22 A
Utilisation category	AC-53B conforming to EN/IEC 60947-4-2
Current consumption	100 mA
Type of start	Start with voltage ramp
Power dissipation in W	2.5 W at full load and at end of starting 222.5 W in transient state

Complementary

Assembly style	With heat sink
Function available	Integrated bypass
Supply voltage limits	180...528 V
Supply frequency	50...60 Hz - 5...5 %
Network frequency	47.5...63 Hz
Output voltage	<= power supply voltage
[Uc] control circuit voltage	24 V DC +/- 10 %
Starting time	1 s / 100 5 s / 20 10 s / 10 Adjustable from 1 to 10 s
Deceleration time symb	Adjustable from 1 to 10 s
Starting torque	30...80 % of starting torque of motor connected directly on the line supply

Excluding VAT and subject to change. Please check with your local distributor through "Where to buy"

Discrete input type	Logic (LI1, LI2, BOOST) stop, run and boost on start-up functions <= 8 mA 27 kOhm
Discrete input voltage	24...40 V
Input output isolation	Galvanic between power and control
Discrete input logic	Positive LI1, LI2, BOOST at State 0: < 5 V and <= 0.2 mA at State 1: > 13 V, >= 0.5 mA
Discrete output current	2 A DC-13 3 A AC-15
Discrete output type	Open collector logic LO1 end of starting signal Relay outputs R1A, R1C NO
Discrete output voltage	24 V (voltage limits: 6...30 V) open collector logic
Minimum switching current	10 mA at 6 V DC for relay outputs
Maximum switching current	Relay outputs: 2 A at 30 V DC cos phi = 0.5 and L/R = 20 ms inductive load Relay outputs: 2 A at 250 V AC AC-15 cos phi = 0.5 and L/R = 20 ms inductive load
Maximum switching voltage	440 V relay outputs
Display type	1 LED (green) for starter powered up 1 LED (yellow) for nominal voltage reached
tightening torque	1.9...2.5 N.m 0.5 N.m
Electrical connection	4 mm screw clamp terminal - rigid 1 1...10 mm ² AWG 8 power circuit Screw connector - rigid without cable end 1 0.5...2.5 mm ² AWG 14 control circuit 4 mm screw clamp terminal - rigid 2 1...6 mm ² AWG 10 power circuit Screw connector - rigid 2 0.5...1 mm ² AWG 17 control circuit Screw connector - flexible with cable end 1 0.5...1.5 mm ² AWG 16 control circuit 4 mm screw clamp terminal - flexible without cable end 1 1.5...10 mm ² AWG 8 power circuit Screw connector - flexible without cable end 1 0.5...2.5 mm ² AWG 14 control circuit 4 mm screw clamp terminal - flexible with cable end 2 1...6 mm ² AWG 10 power circuit 4 mm screw clamp terminal - flexible without cable end 2 1.5...6 mm ² AWG 10 power circuit Screw connector - flexible without cable end 2 0.5...1.5 mm ² AWG 16 control circuit
Marking	CE
Operating position	Vertical +/- 10 degree
Height	314 mm
Width	45 mm
Depth	170 mm
Net weight	0.49 kg
Power range	4...6 kW at 200...240 V 3 phases 7...11 kW at 380...440 V 3 phases
Motor starter type	Soft starter

Environment

Electromagnetic compatibility	Conducted and radiated emissions level B conforming to CISPR 11 Conducted and radiated emissions level B conforming to IEC 60947-4-2 Damped oscillating waves level 3 conforming to IEC 61000-4-12 Electrostatic discharge level 3 conforming to IEC 61000-4-2 EMC immunity conforming to EN 50082-1 EMC immunity level B conforming to EN 50082-2 Harmonics level 3 conforming to IEC 1000-3-2 Harmonics level 3 conforming to IEC 1000-3-4 Immunity to electrical transients level 4 conforming to IEC 61000-4-4 Immunity to radiated radio-electrical interference level 3 conforming to IEC 61000-4-3 Voltage/current impulse level 3 conforming to IEC 61000-4-5 Conducted and radiated emissions level 3 conforming to IEC 61000-4-6 Immunity to conducted interference caused by radio-electrical fields level 4 conforming to IEC 61000-4-11
Standards	EN/IEC 60947-4-2

Product certifications	C-Tick CSA UL CCC
IP degree of protection	IP20
Pollution degree	2 conforming to EN/IEC 60947-4-2
Vibration resistance	1 gn (f= 13...150 Hz) conforming to EN/IEC 60068-2-6 1.5 mm peak to peak (f= 3...13 Hz) conforming to EN/IEC 60068-2-6
Shock resistance	15 gn for 11 ms conforming to EN/IEC 60068-2-27
Relative humidity	5...95 % without condensation or dripping water conforming to EN/IEC 60068-2-3
Ambient air temperature for operation	-10...40 °C (without derating) 40...50 °C (with current derating of 2 % per °C)
Ambient air temperature for storage	-25...70 °C conforming to EN/IEC 60947-4-2
Operating altitude	<= 1000 m without derating > 1000 m with current derating of 2.2 % per additional 100 m

Packing Units

Unit Type of Package 1	PCE
Number of Units in Package 1	1
Package 1 Height	5.000 cm
Package 1 Width	15.000 cm
Package 1 Length	17.200 cm
Package 1 Weight	554.000 g
Unit Type of Package 2	S03
Number of Units in Package 2	14
Package 2 Height	30.000 cm
Package 2 Width	30.000 cm
Package 2 Length	40.000 cm
Package 2 Weight	8.405 kg
Unit Type of Package 3	P06
Number of Units in Package 3	112
Package 3 Height	75.000 cm
Package 3 Width	60.000 cm
Package 3 Length	80.000 cm
Package 3 Weight	77.036 kg

Contractual warranty

Warranty (in months)	18
-----------------------------	----



Environmental Data

Schneider Electric aims to achieve Net Zero status by 2050 through supply chain partnerships, lower impact materials, and circularity via our ongoing “Use Better, Use Longer, Use Again” campaign to extend product lifetimes and recyclability.

[Environmental Data explained >](#)

[How we assess product sustainability >](#)

Use Better



Materials and Substances

Packaging made with recycled cardboard

Yes

Packaging without single use plastic

Yes

[EU RoHS Directive](#)

Pro-active compliance (Product out of EU RoHS legal scope)

REACH Regulation

[REACH Declaration](#)

Use Longer



Lifetime extension

Repair

No

Use Again



Repack and remanufacture

Take-back

No

WEEE Label



The product must be disposed on European Union markets following specific waste collection and never end up in rubbish bins

Dimensions Drawings

Dimensions

With TeSys U Combination (Non Reversing Power Base)

Mounting on symmetrical (35 mm) rail with power connector between ATS and TeSys U.

mm
in.

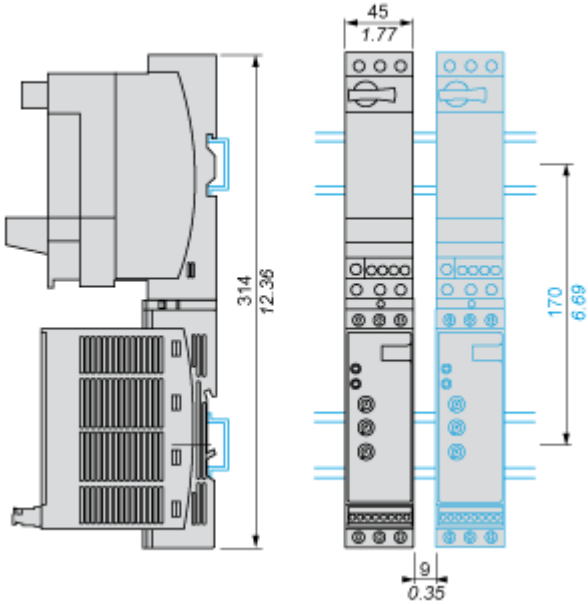

With TeSys U Combination (Non Reversing or Reversing Power Base)

Side by side mounting

mm
in.

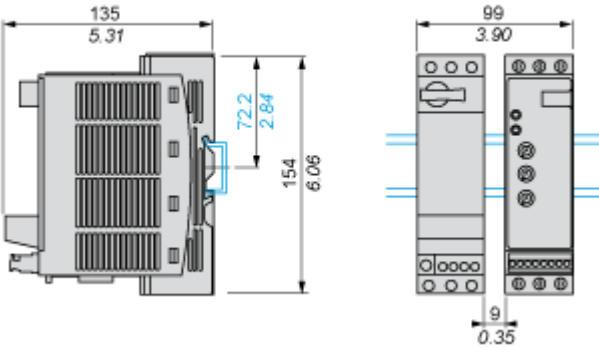

Connections and Schema

Power Wiring

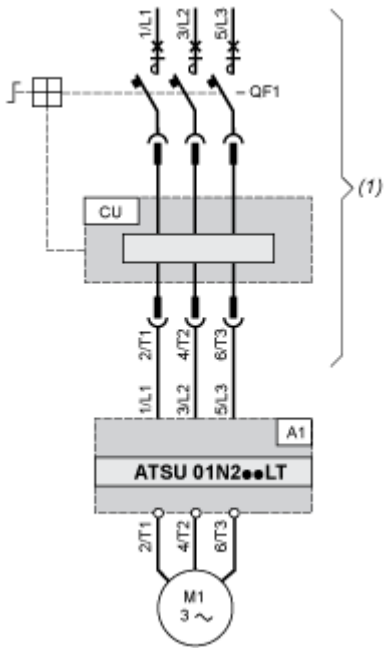

(1) TeSys U

A1 : Soft start/soft stop unit

QF1 : TeSys U controller-starter

CU : TeSys U control unit

With Reversing Unit

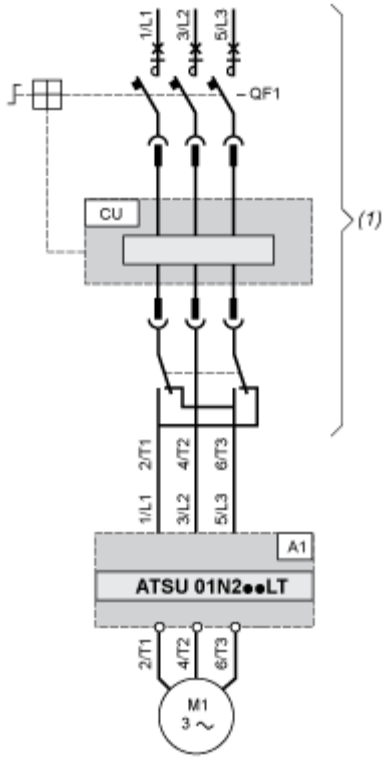

- (1) TeSys U with reversing unit
- A1 : Soft start/soft stop unit
- QF1 : TeSys U controller-starter
- CU : TeSys U control unit

Control Wiring

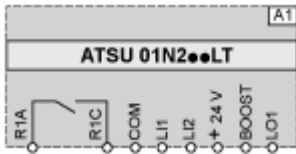

A1 : Soft start/soft stop unit

R1A, R1C : Relay output NO

COM : Commun

LI1, LI2 : Logic inputs (stop and run functions)

BOOST : Logic input (boost on start-up function)

LO1 : Logic output

Technical Description

Functional Diagram Automatic 2-wire Control

Without Deceleration

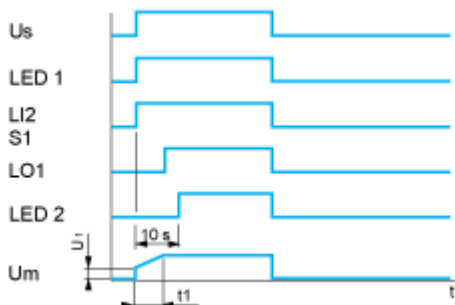

- Us : Power supply voltage
- LED 1 : Green LED
- LI2 : Logic input
- S1 : Pushbutton
- LED 2 : Yellow LED
- Um : Motor voltage
- t1 : Acceleration time can be controlled by a potentiometer
- U1 : Starting time can be controlled by a potentiometer

With and without Deceleration

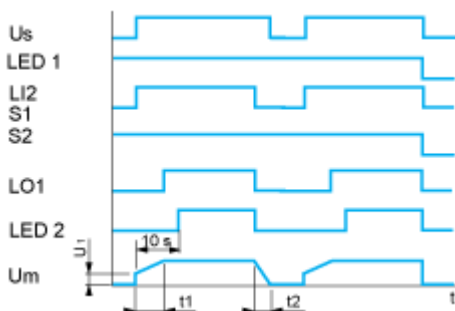

- Us : Power supply voltage
- LED 1 : Green LED
- LI2 : Logic input
- S1, S2 : Pushbuttons
- LO1 : Logic output
- LED 2 : Yellow LED
- Um : Motor voltage
- t1 : Acceleration time can be controlled by a potentiometer
- t2 : Deceleration time can be controlled by a potentiometer
- U1 : Starting time can be controlled by a potentiometer

Functional Diagram Automatic 3-wire Control

Without Deceleration

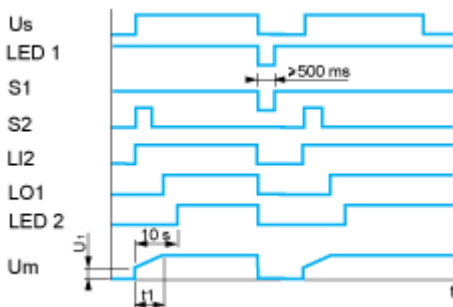

U_s : Power supply voltage

$LED\ 1$: Green LED

$S1, S2$: Pushbuttons

$LI2$: Logic input

$LO1$: Logic output

$LED\ 2$: Yellow LED

U_m : Motor voltage

t_1 : Acceleration time can be controlled by a potentiometer

$U1$: Starting time can be controlled by a potentiometer

With Deceleration

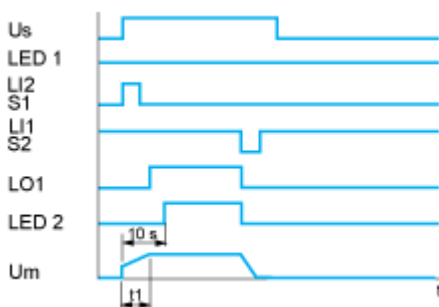

U_s : Power supply voltage

$LED\ 1$: Green LED

$S1, S2$: Pushbuttons

$LI1, LI2$: Logic inputs

$LO1$: Logic output

$LED\ 2$: Yellow LED

U_m : Motor voltage

t_1 : Acceleration time can be controlled by a potentiometer