

# Product datasheet

Specifications



## Soft starter, Altivar Soft Starter ATS490, 1200A, 208 to 690V AC, control supply 110 to 230V AC

ATS490M12Y

### Main

Range of product	Altivar Soft Starter ATS490
Product or component type	Soft starter
Product destination	Asynchronous motors
Product specific application	Process and infrastructures
Device short name	ATS490
Network number of phases	3 phases
Utilisation category	AC-3A AC-53A
Ue power supply voltage	208...690 V AC (- 15...10 %)
power supply frequency	50...60 Hz - 20...20 %
[Ie] rated operational current	Normal duty: 1200 A in line (at <40 °C) Heavy duty: 1045 A in line (at <40 °C)
Service factor at Ie	100
rated current in heavy duty	1045 A at 40 °C for heavy duty
IP degree of protection	IP00
Motor power kW	355 kW at 230 V in the motor supply line normal duty 630 kW at 400 V in the motor supply line normal duty 710 kW at 440 V in the motor supply line normal duty 800 kW at 500 V in the motor supply line normal duty 800 kW at 525 V in the motor supply line normal duty 250 kW at 230 V in the motor supply line heavy duty 500 kW at 400 V in the motor supply line heavy duty 630 kW at 440 V in the motor supply line heavy duty 630 kW at 500 V in the motor supply line heavy duty 630 kW at 525 V in the motor supply line heavy duty 900 kW at 660 V in the motor supply line heavy duty 900 kW at 690 V in the motor supply line heavy duty 500 kW at 230 V to the motor delta terminals normal duty 710 kW at 400 V to the motor delta terminals heavy duty
Motor power hp	400 hp at 208 V normal duty 450 hp at 230 V normal duty 1000 hp at 460 V normal duty 1200 hp at 575 V normal duty 350 hp at 208 V heavy duty 350 hp at 230 V heavy duty 800 hp at 460 V heavy duty 1000 hp at 575 V heavy duty
With safety function Safe torque off (STO)	True
Safe Torque Off (STO)	STO (safe torque off): SIL 1 conforming to IEC 61508 STO (safe torque off): PL c/category 2 conforming to ISO 13849
Cybersecurity functions	True
Cybersecurity level and standard	Security level (SL) 1 conforming to IEC 62443-4-2

Excluding VAT and subject to change. Please check with your local distributor through "Where to buy"

<b>Communication port protocol</b>	Modbus serial Modbus TCP/EtherNet/IP
<b>Option card</b>	Communication module for CANopen daisy chain Communication module for CANopen Sub-D Communication module for CANopen open style Communication module for Profibus DP V1 Communication module for PROFINET

## Complementary

<b>Device connection</b>	In the motor supply line Inside delta
<b>Overload current profile</b>	400 % I <sub>e</sub> for 13 s
<b>On-load factor</b>	50 %
<b>Operating cycles/hour</b>	10 cyc/h
<b>[Us] control circuit voltage</b>	110...230 V AC 50...60 Hz - 15...10 %
<b>Apparent power</b>	300 VA
<b>Integrated motor overload protection</b>	True
<b>motor thermal protection class</b>	Class 10E
<b>Protection type</b>	Phase failure: mains Thermal protection: starter Thermal protection: motor Current overload: motor Motor underload: motor Excessive acceleration time: motor Motor phase loss detection: motor Protection against line phase inversion: mains External thermal protection: motor Protection delta inside wiring: starter Short-circuit between motor phase and earth: motor
<b>current limiting %I<sub>n</sub> (5 x I<sub>e</sub> maximum)</b>	150...700 %
<b>Rated current pwr loss specification</b>	1200 A
<b>Power loss static current independent</b>	19 W
<b>Power loss per device current dependent</b>	361 W
<b>Power loss during starting</b>	18724 W during starting at 40 °C at 400% I <sub>e</sub>
<b>Standards</b>	EN/IEC 60947-4-2 UL 60947-4-2 IEC 60664-1
<b>Product certifications</b>	CE UKCA RCM CCC DNV ATEX EAC KC cULus
<b>Marking</b>	CE UKCA RCM CCC ATEX EAC KC CULus
<b>[Uc] control circuit voltage</b>	24 V DC
<b>Discrete input number</b>	5

<b>Discrete input type</b>	(DI1) digital input, 4.4 kOhm (DI2) digital input, 4.4 kOhm (DI3) digital input, 4.4 kOhm (DI4) digital input, 4.4 kOhm (STO) digital input, > 1 kOhm
<b>Input compatibility</b>	DI1: discrete input level 1 PLC conforming to EN/IEC 61131-2 DI2: discrete input level 1 PLC conforming to EN/IEC 61131-2 DI3: discrete input level 1 PLC conforming to EN/IEC 61131-2 DI4: discrete input level 1 PLC conforming to EN/IEC 61131-2 STO: discrete input level 1 PLC conforming to EN/IEC 61131-2
<b>Discrete input logic</b>	Digital input DI1 at State 0: 0...< 5 V and <= 2 mA at State 1: > 11 V, >= 5 mA Digital input DI2 at State 0: 0...< 5 V and <= 2 mA at State 1: > 11 V, >= 5 mA Digital input DI3 at State 0: 0...< 5 V and <= 2 mA at State 1: > 11 V, >= 5 mA Digital input DI4 at State 0: 0...< 5 V and <= 2 mA at State 1: > 11 V, >= 5 mA Digital input STO at State 0: 0...< 5 V and <= 2 mA at State 1: > 11 V, >= 5 mA
<b>Relay output number</b>	3
<b>Relay output type</b>	Relay outputs R1A, R1C NO Relay outputs R2A, R2C NO Relay outputs R3A, R3C NO
<b>Minimum switching current</b>	100 mA at 12 V DC for relay outputs
<b>Maximum switching current</b>	Relay outputs 2 A / 250 V AC for AC-15 100000 cycles following IEC 60947-5-1 Relay outputs 2 A / 30 V DC for DC-13 150000 cycles following IEC 60947-5-1
<b>Discrete output number</b>	2
<b>Discrete output type</b>	Programmable digital output DQ1 <= 30 V 100 mA Programmable digital output DQ2 <= 30 V 100 mA
<b>Output compatibility</b>	Open collector level 1 PLC conforming to IEC 65A-68
<b>Analogue input number</b>	1
<b>Analogue input type</b>	AI1/PTC1 : PTC/PT 100/PT 1000/KTY84 temperature probe PTC2 : PTC/PT 100/PT 1000/KTY84 temperature probe PTC3 : PTC/PT 100/PT 1000/KTY84 temperature probe
<b>Analogue output number</b>	1
<b>Analogue output type</b>	Current output AQ1 : 0...20 mA/4...20 mA , impedance< 500 Ohm Voltage output AQ1 : 0...10 V , impedance> 470 Ohm
<b>Communication port protocol</b>	Modbus serial Modbus TCP/EtherNet/IP EtherNet/IP
<b>Connector type</b>	1 RJ45 for connecting Modbus serial 1 RJ45 for connecting Modbus TCP/EtherNet/IP
<b>Physical interface</b>	2-wire RS 485 100-BASE-TX category 5 or industrial Ethernet
<b>Transmission frame</b>	RTU TCP/UDP
<b>Transmission rate</b>	4.8...38.4 kbps 100 BASE TX
<b>Data format</b>	8 bits, configurable odd, even or no parity 1 or 2 stop
<b>Number of addresses</b>	0...247 for Modbus serial
<b>Method of access</b>	Slave Modbus serial
<b>Type of polarization</b>	No impedance for Modbus serial No impedance for Modbus TCP No impedance for EtherNet/IP
<b>Display screen available</b>	True
<b>Operating position</b>	Vertical +/- 10 degree
<b>Height</b>	580 mm
<b>Width</b>	436 mm

Depth	350 mm
Net weight	65 kg
internal bypass	True
Function available	Pre-heating Smoke extraction Second motor set Deceleration with torque control Braking Boost Line contactor control Reverse contactor control Anti-jam Jog Borehole pump starting Condition monitoring Power monitoring Cybersecure firmware update
material declaration	True

## Environment

Electromagnetic compatibility	Conducted and radiated emissions level A conforming to IEC 60947-4-2 Damped oscillating waves level 3 conforming to IEC 61000-4-18 Electrostatic discharge level 3 conforming to IEC 61000-4-2 Immunity to electrical transients level 4 conforming to IEC 61000-4-4 Immunity to radiated radio-electrical interference level 3 conforming to IEC 61000-4-3 Voltage/current impulse level 3 conforming to IEC 61000-4-5 Immunity to conducted interference caused by radio-electrical fields level 3 conforming to EN/IEC 61000-4-6
Pollution degree	Level 3
[Uimp] rated impulse withstand voltage	6 kV
[Ui] rated insulation voltage	690 V
Environmental class (during operation)	Class 3C3 according to IEC 60721-3-3 Class 3S3 according to IEC 60721-3-3
Ambient air temperature for operation	-25...40 °C (without derating) 40...60 °C (with current derating of 1 % per °C above 40 °C)
Ambient air temperature for storage	-40...70 °C
Ambient air transport temperature	-40...70 °C
Operating altitude	<= 2000 m without derating > 2000...4800 m with current derating 1 % per 100 m above 2000 m
Relative humidity	5...95 % without condensation or dripping water conforming to EN/IEC 60068-2-3
Maximum deflection under vibratory load (during operation)	1.5 mm at 2...13 Hz
Maximum deflection under vibratory load (during storage)	1.75 mm at 2...9 Hz
Maximum deflection under vibratory load (during transport)	1.75 mm at 2...9 Hz
Maximum acceleration under vibrational stress (during operation)	1 gn at 13...200 Hz
Maximum acceleration under vibratory load (during storage)	1 gn at 9...200 Hz 1.5 gn at 200...500 Hz
Maximum acceleration under vibratory load (during transport)	1 gn at 9...200 Hz 1.5 gn at 200...500 Hz
Maximum acceleration under shock impact (during operation)	15 gn at 11 ms
Maximum acceleration under shock load (during storage)	10 gn at 11 ms
Maximum acceleration under shock load (during transport)	10 gn at 11 ms

# Packing Units

Unit Type of Package 1	PCE
Number of Units in Package 1	1
Package 1 Height	59.000 cm
Package 1 Width	60.000 cm
Package 1 Length	80.000 cm
Package 1 Weight	86.000 kg



## Environmental Data

Schneider Electric aims to achieve Net Zero status by 2050 through supply chain partnerships, lower impact materials, and circularity via our ongoing “Use Better, Use Longer, Use Again” campaign to extend product lifetimes and recyclability.

[Environmental Data explained >](#)

[How we assess product sustainability >](#)

### Environmental footprint

Total lifecycle Carbon footprint 9699

Environmental Disclosure [Product Environmental Profile](#)

## Use Better

### Materials and Substances

Packaging made with recycled cardboard Yes

Packaging without single use plastic No

[EU RoHS Directive](#) Compliant with Exemptions

SCIP Number D03e37f0-1ba5-467b-bdf3-5355bb2c8efe

REACH Regulation [REACH Declaration](#)

PVC free Yes

## Use Longer

### Lifetime extension

Repair No

## Use Again

### Repack and remanufacture

End of life manual availability [End of Life Information](#)

Removable battery Yes

Take-back No

WEEE Label The product must be disposed on European Union markets following specific waste collection and never end up in rubbish bins



Mounting and Clearance

**Mounting Position**

---

The soft starter is designed to be mounted inside cabinets vertically at  $\pm 10^\circ$  for cooling purposes. Respect the minimum clearances so that the cooling air can circulate from the bottom to the top of the soft starter. The minimum clearances apply to any device close to the soft starter such as circuit breakers, fuses and contactors. Do not install the soft starter above heating elements.

mm  
in

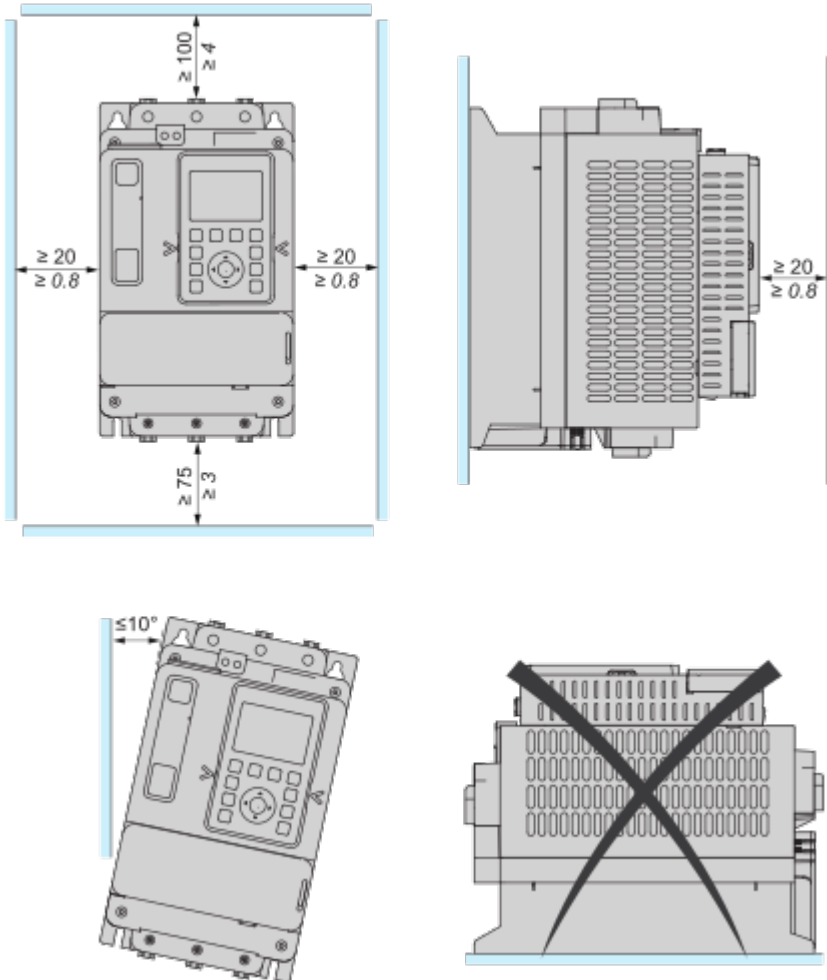

Connections and Schema

Wiring

Wiring the Power Part

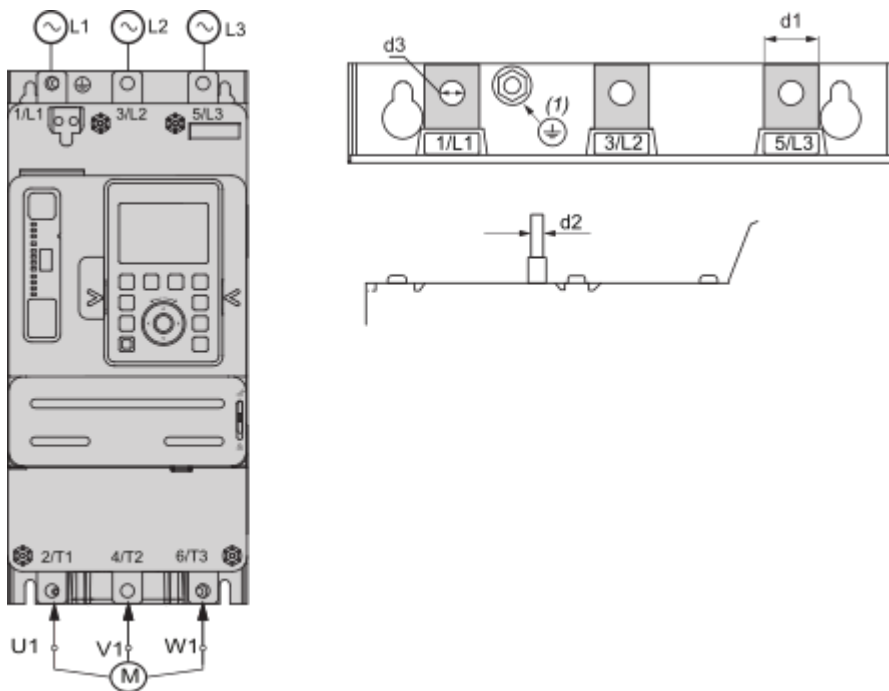

1/L1, 3/L2, 5/L3 : Mains supply inputs

2/T1, 4/T2, 6/T3 : Outputs to motor

(1) : Ground connection

Connection In Line, No Line Contactor, Type 1 or 2 Coordination, 2-wire or 3-wire control

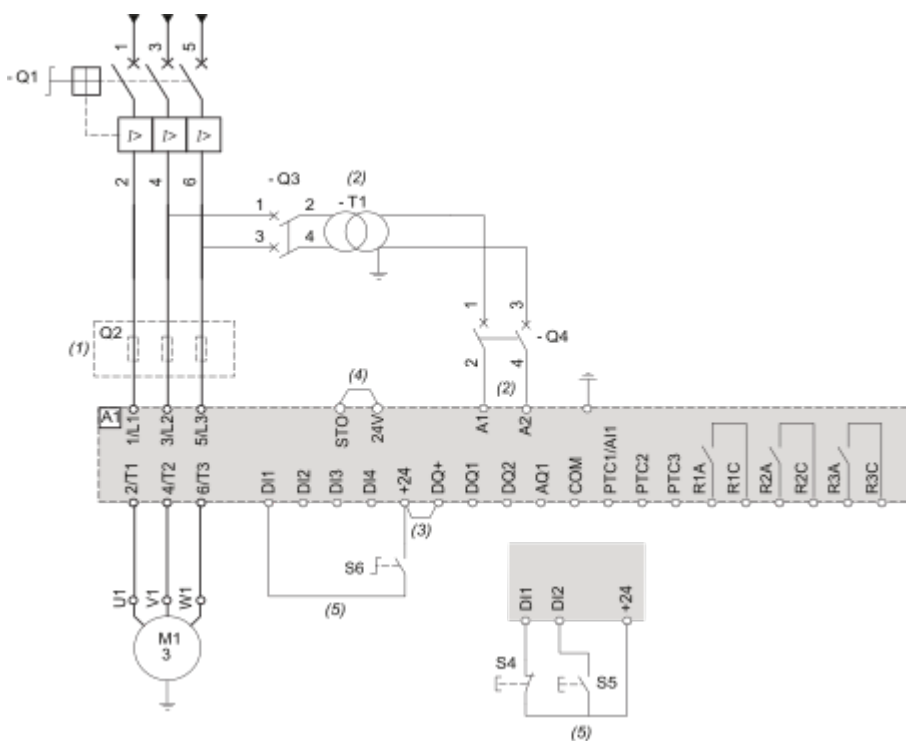

(1) : Installation of additional fast-acting fuses is mandatory to upgrade to type 2 coordination according to IEC 60947-4-2.

- (2) : The transformer must supply 110...230 Vac +10% - 15%, 50/60Hz.
- (3) : 24Vdc supply on DQ+ if usage of DQ outputs.
- (4) : STO Safe Torque Off
- (5) : 3-wire control and 2-wire control.

Designation	Component	Description
Q1	Circuit breaker	Short circuit protection device for the motor
Q2	Fast acting fuses	Short circuit protection device of the soft starter to be used only when type 2 coordination
Q3	Circuit breaker	Short circuit protection device for the primary of the transformer
Q4	Circuit breaker	Short circuit protection device for the secondary of the transformer
S4	Normally close contact push- button	STOP command for 3-wire control
S5	Normally open contact push- button	RUN command for 3-wire control
S6	Selector switch, 2 positions, stay-put, normally open contact	RUN/STOP command for 2-wire control

**Connection In Line, With Line Contactor, Type 1 or 2 Coordination, 2-wire or 3-wire control**

Line contactor controlled by Power ON and Power OFF push-buttons or on detected error  
 Use relay output R1 set to [Operating State Fault] (factory setting)



- (1) : Installation of additional fast-acting fuses is mandatory to upgrade to type 2 coordination according to IEC 60947-4-2.
- (2) : Take into account the electrical characteristics of the relays.
- (3) : The transformer must supply 110...230 Vac +10% - 15%, 50/60Hz.
- (4) : 3-wire control and 2-wire control.

(5) : Select the appropriate voltage surge suppressor.

(6) : STO Safe Torque Off

Designation	Component	Description
Q1	Circuit breaker	Short circuit protection device for the motor
Q2	Circuit breaker	Short circuit protection device for the primary of the transformer
Q3	Fast acting fuses	Short circuit protection device of the soft starter to be used only when type 2 coordination
Q4	Circuit breaker	Short circuit protection device for the secondary of the transformer
Q5	Circuit breaker	Short circuit protection device for the control part of the soft starter
KM1	Contacteur	Line contactor
S1	Emergency Stop push-button	Emergency Stop to de-energized KM1 line contactor
S2	Normally close push-button	Power OFF
S3	Normally open push-button	Power ON
S4	Normally close contact push-button	STOP command for 3-wire control
S5	Normally open contact push-button	RUN command for 3-wire control
S6	Selector switch, 2 positions, stay-put, normally open contact	RUN/STOP command for 2-wire control

**Connection In Line, With Line Contactor, Type 1 or 2 Coordination, 2-wire control**

Line contactor controlled based on RUN & STOP or on detected error.

Use relay output R1 set to [Mains Contactor]

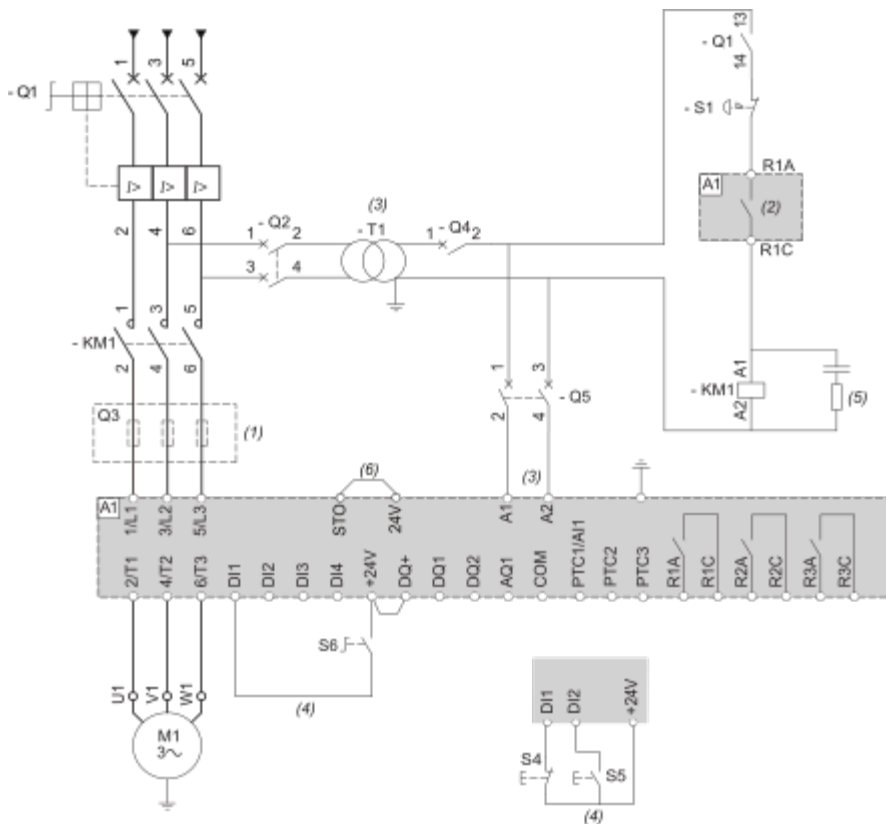

- (1) : Installation of additional fast-acting fuses is mandatory to upgrade to type 2 coordination according to IEC 60947-4-2.
- (2) : Take into account the electrical characteristics of the relays.
- (3) : The transformer must supply 110...230 Vac +10% - 15%, 50/60Hz.
- (4) : 2-wire control and 3-wire control.
- (5) : Select the appropriate voltage surge suppressor.
- (6) : STO Safe Torque Off.

Designation	Component	Description
Q1	Circuit breaker	Short circuit protection device for the motor
Q2	Circuit breaker	Short circuit protection device for the primary of the transformer
Q3	Fast acting fuses	Short circuit protection device of the soft starter to be used only when type 2 coordination according to IEC 60947-4-2 is required
Q4	Circuit breaker	Short circuit protection device for the secondary of the transformer
Q5	Circuit breaker	Short circuit protection device for the control part of the soft starter
KM1	Contactor	Line contactor
S1	Emergency Stop push-button	Emergency Stop to de-energized KM1 line contactor
S4	Normally close contact push-button	STOP command for 3-wire control
S5	Normally open contact push-button	RUN command for 3-wire control

S6	Selector switch, 2 positions, stay-put, normally open contact	RUN/STOP. command for 2-wire control
----	---	--------------------------------------

**Connection Inside the Delta, Type 1 and 2 Coordination, 2-wire or 3-wire**

Line contactor controlled based on RUN and STOP command or detected error

Use relay output R1 set to [Operating State Fault] (factory setting).

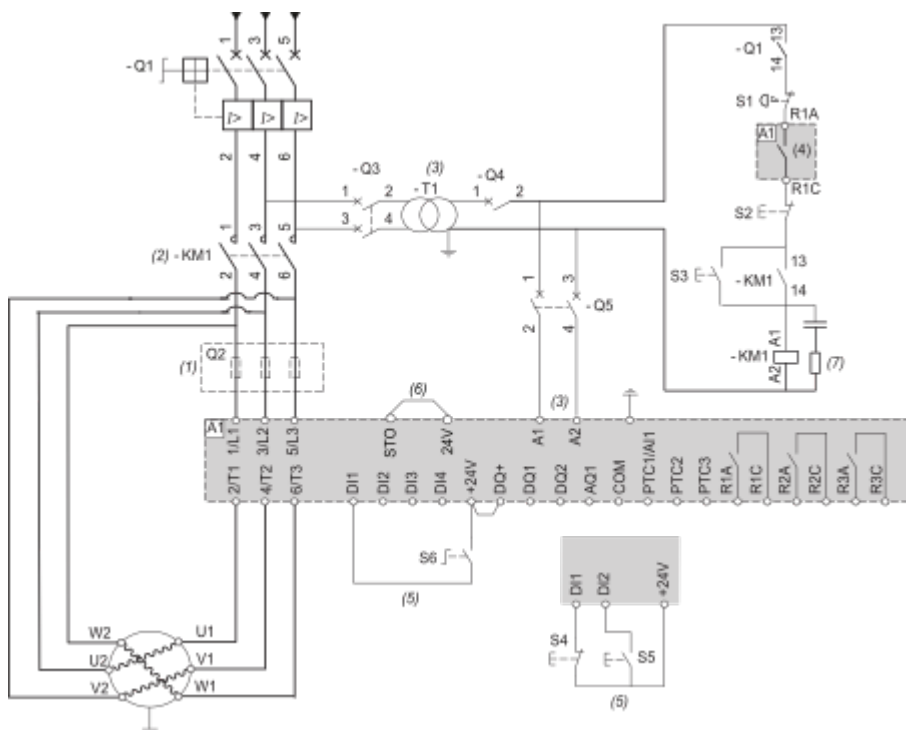

- (1) : Installation of additional fast-acting fuses is mandatory to upgrade to type 2 coordination according to IEC 60947-4-2.
- (2) : KM1 is mandatory to avoid uncontrolled voltage on the motor.
- (3) : The transformer must supply 110...230 Vac +10% — 15%, 50/60Hz.
- (4) : Take into account the electrical characteristics of the relays, especially when connecting to high rating contactor.
- (5) : 3-wire control, 2-wire control.
- (6) : STO Safe Torque Off.
- (7) : Select the appropriate voltage surge suppressor.

Designation	Component	Description
Q1	Circuit breaker	Short circuit protection device for the motor
Q2	Fast acting fuses	Short circuit protection device of the soft starter to be used only when type 2 coordination according to IEC 60947-4-2 is required
Q3	Circuit breaker	Short circuit protection device for the primary of the transformer
Q4	Circuit breaker	Short circuit protection device for the secondary of the transformer
Q5	Circuit breaker	Short circuit protection device for the control part of the soft starter
KM1	Contacteur	Line contactor
S1	Emergency Stop push-button	Emergency Stop to de-energized KM1 line contactor

S2	Normally close push-button	Power OFF
S3	Normally open push-button	Power ON
S4	Normally close contact push-button	STOP command for 3-wire control
S5	Normally open contact push-button	RUN command for 3-wire control
S6	Selector switch, 2 positions, stay-put, normally open contact	RUN/STOP. command for 2-wire control

**Connection Inside the Delta, Type 1 or 2 Coordination, 2-wire or 3-wire**

Line contactor controlled based on RUN and STOP command or detected error

Use relay output R1 set to [Mains Contactor]

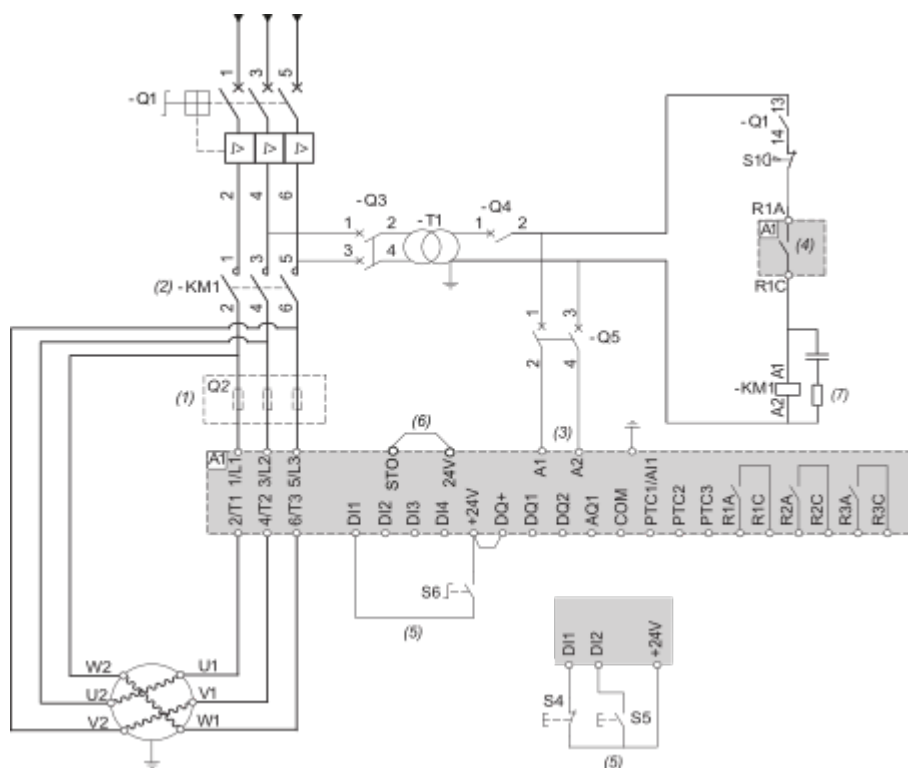

- (1) : Installation of additional fast-acting fuses is mandatory to upgrade to type 2 coordination according to IEC 60947-4-2.
- (2) : KM1 is mandatory to avoid uncontrolled voltage on the motor.
- (3) : The transformer must supply 110...230 Vac +10% — 15%, 50/60Hz.
- (4) : Take into account the electrical characteristics of the relays.
- (5) : 3-wire control and 2-wire control.
- (6) : STO Safe Torque Off.
- (7) : Select the appropriate voltage surge suppressor.

Designation	Component	Description
Q1	Circuit breaker	Short circuit protection device for the motor
Q2	Circuit breaker	Short circuit protection device for the primary of the transformer

Q3	Fast acting fuses	Short circuit protection device of the soft starter to be used only when type 2 coordination
Q4	Circuit breaker	Short circuit protection device for the secondary of the transformer
Q5	Circuit breaker	Short circuit protection device for the control part of the soft starter
KM1	Contactors	Line contactor
S1	Emergency Stop push-button	Emergency Stop to de-energized KM1 line contactor
S4	Normally close contact push-button	STOP command for 3-wire control and power Off
S5	Normally open contact push-button	RUN command for 3-wire control and power On
S6	Selector switch, 2 positions, stay-put, normally open contact	RUN/STOP command for 2-wire control

Control Block Wiring Diagram

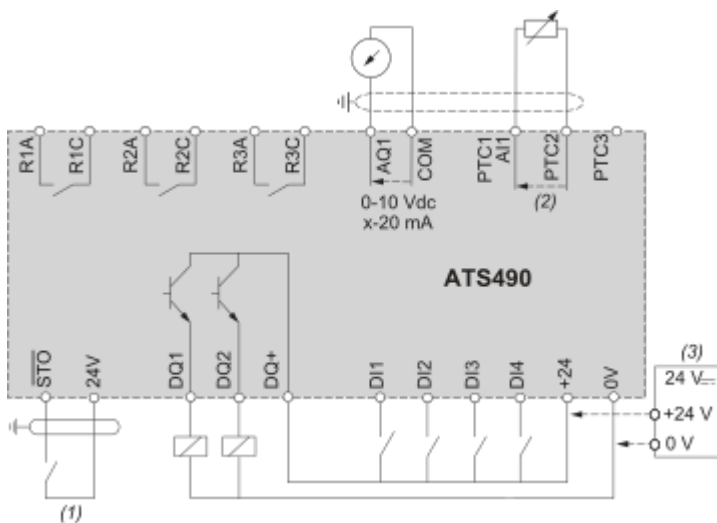

R1A, R1C, R2A, R2C, R3A, R3C : Programmable NO relays

DI1, DI2, DI3, DI4 : Digital inputs

AQ1 : Analogue output

PTC1/AI1, PTC2, PTC3 : Motor thermal sensor connection

DQ1, DQ2, DQ+ : Digital outputs

STO : Safety function STO input

(1) : STO Safe Torque Off

(2) : 2 wire PTC/PT100/PT1000/KTY

(3) : Optional, in case of +24 External Supply usage

PT100, PT1000 Thermal Probe 3 Wires :



(4) : 3 wire PT100/PT1000

Technical Illustration

Dimensions

---

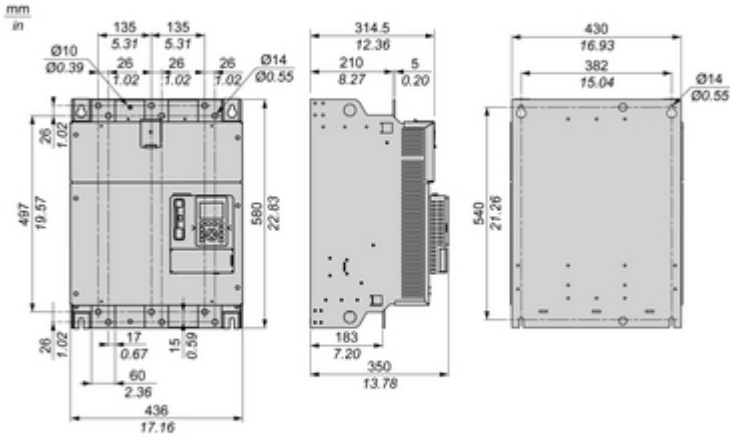

Technical Illustration

Wiring diagram



Image of product / Alternate images

Alternative

---



