

Product datasheet

Specifications



Variable speed drive. Altivar Machine ATV340. 2.2 kW Heavy Duty. 400 V. 3 phases. Ethernet

ATV340U22N4E

Price: 18,825.06 ZAR

Main

| | |
|------------------------------|---|
| Range of product | Altivar Machine ATV340 |
| Product or component type | Variable speed drive |
| Product specific application | Machine |
| Mounting mode | Cabinet mount |
| Variant | Standard version |
| Communication port protocol | Modbus TCP Modbus serial EtherNet/IP |
| Network number of phases | 3 phases |
| Supply frequency | 50...60 Hz +/- 5 % |
| [Us] rated supply voltage | 380...480 V - 15...10 % |
| nominal output current | 5.6 A |
| Motor power kW | 3 kW for normal duty 2.2 kW for heavy duty |
| Motor power hp | 3 hp for normal duty 3 hp for heavy duty |
| EMC filter | Class C3 EMC filter integrated |
| IP degree of protection | IP20 |

Complementary

| | |
|-------------------------|---|
| Discrete input number | 5 |
| Discrete input type | PT1 programmable as pulse input: 0...30 kHz, 24 V DC (30 V) DI1...DI5 safe torque off, 24 V DC (30 V), impedance: 3.5 kOhm programmable |
| number of preset speeds | 16 preset speeds |
| Discrete output number | 2.0 |
| Discrete output type | Programmable output DQ1, DQ2 30 V DC 100 mA |
| Analogue input number | 2 |
| Analogue input type | A11 software-configurable current: 0...20 mA, impedance: 250 Ohm, resolution 12 bits A11 software-configurable temperature probe or water level sensor A1 software-configurable voltage: 0...10 V DC, impedance: 31.5 kOhm, resolution 12 bits A12 software-configurable voltage: - 10...10 V DC, impedance: 31.5 kOhm, resolution 12 bits |
| Analogue output number | 1 |

Excluding VAT and subject to change. Please check with your local distributor through "Where to buy"

| | |
|--|--|
| Analogue output type | Software-configurable voltage AQ1: 0...10 V DC impedance 470 Ohm, resolution 10 bits Software-configurable current AQ1: 0...20 mA impedance 500 Ohm, resolution 10 bits |
| Relay output number | 2 |
| Output voltage | <= power supply voltage |
| Relay output type | Relay outputs R1A Relay outputs R1C electrical durability 100000 cycles Relay outputs R2A Relay outputs R2C electrical durability 100000 cycles |
| Maximum switching current | Relay output R1C on resistive load, cos phi = 1: 3 A at 250 V AC Relay output R1C on resistive load, cos phi = 1: 3 A at 30 V DC Relay output R1C on inductive load, cos phi = 0.4 and L/R = 7 ms: 2 A at 250 V AC Relay output R1C on inductive load, cos phi = 0.4 and L/R = 7 ms: 2 A at 30 V DC Relay output R2C on resistive load, cos phi = 1: 5 A at 250 V AC Relay output R2C on resistive load, cos phi = 1: 5 A at 30 V DC Relay output R2C on inductive load, cos phi = 0.4 and L/R = 7 ms: 2 A at 250 V AC Relay output R2C on inductive load, cos phi = 0.4 and L/R = 7 ms: 2 A at 30 V DC |
| Minimum switching current | Relay output R1B: 5 mA at 24 V DC Relay output R2C: 5 mA at 24 V DC |
| Physical interface | 2-wire RS 485 |
| Connector type | 3 RJ45 |
| Method of access | Slave Modbus RTU Slave Modbus TCP |
| Transmission rate | 4.8 kbit/s 9.6 kbit/s 19.2 kbit/s 38.4 kbit/s |
| Transmission frame | RTU |
| Number of addresses | 1...247 |
| Data format | 8 bits, configurable odd, even or no parity |
| Type of polarization | No impedance |
| 4 quadrant operation possible | True |
| Asynchronous motor control profile | Constant torque standard Variable torque standard Optimized torque mode |
| Synchronous motor control profile | Permanent magnet motor Reluctance motor |
| Pollution degree | 2 conforming to IEC 61800-5-1 |
| Maximum output frequency | 0.599 kHz |
| Acceleration and deceleration ramps | S, U or customized Linear adjustable separately from 0.01...9999 s |
| Motor slip compensation | Not available in permanent magnet motor law Automatic whatever the load Adjustable Can be suppressed |
| Switching frequency | 2...16 kHz adjustable 4...16 kHz with derating factor |
| Nominal switching frequency | 4 kHz |
| Braking to standstill | By DC injection |
| Brake chopper integrated | True |
| Line current | 6.6 A at 380 V (normal duty) 5.3 A at 480 V (normal duty) 8.4 A at 380 V (heavy duty) 6.6 A at 480 V (heavy duty) |

| | |
|---|--|
| Line current | 8.4 A at 380 V without line choke (heavy duty) 6.6 A at 480 V without line choke (heavy duty) 6.6 A at 380 V with external line choke (normal duty) 5.3 A at 480 V with external line choke (normal duty) 5.1 A at 380 V with external line choke (heavy duty) 4.1 A at 480 V with external line choke (heavy duty) |
| Maximum input current | 8.4 A |
| Maximum output voltage | 480 V |
| Apparent power | 5.2 kVA at 480 V (normal duty) 5.5 kVA at 480 V (heavy duty) |
| Maximum transient current | 7.9 A during 60 s (normal duty) 9.7 A during 2 s (normal duty) 10.1 A during 2 s (heavy duty) 8 A during 60 s (heavy duty) |
| Electrical connection | Screw terminal, clamping capacity: 1.5...4 mm ² for line side Screw terminal, clamping capacity: 4...6 mm ² for DC bus Screw terminal, clamping capacity: 1.5...4 mm ² for motor Screw terminal, clamping capacity: 0.2...2.5 mm ² for control |
| Prospective line Isc | 5 kA |
| Base load current at high overload | 5.6 A |
| Base load current at low overload | 7.2 A |
| Power dissipation in W | Natural convection: 65 W at 380 V, switching frequency 4 kHz (heavy duty) Forced convection: 65 W at 380 V, switching frequency 4 kHz (heavy duty) Natural convection: 80 W at 380 V, switching frequency 4 kHz (normal duty) Forced convection: 80 W at 380 V, switching frequency 4 kHz (normal duty) |
| Electrical connection | Line side: screw terminal 1.5...4 mm ² /AWG 14...AWG 12 DC bus: screw terminal 4...6 mm ² /AWG 12...AWG 10 Motor: screw terminal 1.5...4 mm ² /AWG 14...AWG 12 Control: screw terminal 0.2...2.5 mm ² /AWG 24...AWG 12 |
| With safety function Safely Limited Speed (SLS) | True |
| With safety function Safe brake management (SBC/SBT) | True |
| With safety function Safe Operating Stop (SOS) | False |
| With safety function Safe Position (SP) | False |
| With safety function Safe programmable logic | False |
| With safety function Safe Speed Monitor (SSM) | False |
| With safety function Safe Stop 1 (SS1) | True |
| With sft fct Safe Stop 2 (SS2) | False |
| With safety function Safe torque off (STO) | True |
| With safety function Safely Limited Position (SLP) | False |
| With safety function Safe Direction (SDI) | False |

| | |
|----------------------------------|---|
| Protection type | Thermal protection: motor Safe torque off: motor Motor phase loss: motor Thermal protection: drive Safe torque off: drive Overheating: drive Overcurrent: drive Output overcurrent between motor phase and earth: drive Output overcurrent between motor phases: drive Short-circuit between motor phase and earth: drive Short-circuit between motor phases: drive Motor phase loss: drive DC Bus overvoltage: drive Line supply overvoltage: drive Line supply undervoltage: drive Input supply loss: drive Exceeding limit speed: drive Break on the control circuit: drive |
| Width | 85.0 mm |
| Height | 270.0 mm |
| Depth | 232.5 mm |
| Net weight | 1.8 kg |
| Continuous output current | 7.2 A at 4 kHz for normal duty 5.6 A at 4 kHz for heavy duty |

Environment

| | |
|---|--|
| Operating altitude | <= 3000 m with current derating above 1000m |
| Operating position | Vertical +/- 10 degree |
| Product certifications | UL CSA TÜV EAC CTick |
| Marking | CE |
| Standards | IEC 61800-3 IEC 61800-5-1 IEC 60721-3 IEC 61508 IEC 13849-1 UL 618000-5-1 UL 508C |
| Assembly style | With heat sink |
| Electromagnetic compatibility | Electrostatic discharge immunity test level 3 conforming to IEC 61000-4-2 Radiated radio-frequency electromagnetic field immunity test level 3 conforming to IEC 61000-4-3 Electrical fast transient/burst immunity test level 4 conforming to IEC 61000-4-4 1.2/50 µs - 8/20 µs surge immunity test level 3 conforming to IEC 61000-4-5 Conducted radio-frequency immunity test level 3 conforming to IEC 61000-4-6 |
| Environmental class (during operation) | Class 3C3 according to IEC 60721-3-3 Class 3S3 according to IEC 60721-3-3 |
| Maximum acceleration under shock impact (during operation) | 70 m/s ² at 22 ms |
| Maximum acceleration under vibrational stress (during operation) | 5 m/s ² at 9...200 Hz |
| Maximum deflection under vibratory load (during operation) | 1.5 mm at 2...9 Hz |
| Permitted relative humidity (during operation) | Class 3K5 according to EN 60721-3 |
| Volume of cooling air | 18.0 m ³ /h |
| Type of cooling | Forced convection |
| Overvoltage category | Class III |

| | |
|---------------------------------------|---|
| Regulation loop | Adjustable PID regulator |
| Noise level | 55.4 dB |
| Pollution degree | 2 |
| Ambient air transport temperature | -40...70 °C |
| Ambient air temperature for operation | -15...50 °C without derating (vertical position) 50...60 °C with derating factor (vertical position) |
| Ambient air temperature for storage | -40...70 °C |
| Isolation | Between power and control terminals |

Packing Units

| | |
|------------------------------|-----------|
| Unit Type of Package 1 | PCE |
| Number of Units in Package 1 | 1 |
| Package 1 Height | 11.000 cm |
| Package 1 Width | 37.500 cm |
| Package 1 Length | 31.500 cm |
| Package 1 Weight | 2.524 kg |
| Unit Type of Package 2 | S06 |
| Number of Units in Package 2 | 14 |
| Package 2 Height | 75.000 cm |
| Package 2 Width | 60.000 cm |
| Package 2 Length | 80.000 cm |
| Package 2 Weight | 48.182 kg |

Contractual warranty

| | |
|----------------------|----|
| Warranty (in months) | 18 |
|----------------------|----|



Environmental Data

Schneider Electric aims to achieve Net Zero status by 2050 through supply chain partnerships, lower impact materials, and circularity via our ongoing “Use Better, Use Longer, Use Again” campaign to extend product lifetimes and recyclability.

[Environmental Data explained >](#)

[How we assess product sustainability >](#)

Environmental footprint

Total lifecycle Carbon footprint 2169

Environmental Disclosure [Product Environmental Profile](#)

Use Better

Materials and Substances

Packaging made with recycled cardboard Yes

Packaging without single use plastic Yes

[EU RoHS Directive](#)

Pro-active compliance (Product out of EU RoHS legal scope)

SCIP Number

81d6792e-d307-4115-9475-2db3f34c93af

REACH Regulation

[REACH Declaration](#)

Energy efficiency

Product contributes to saved and avoided emissions Yes

Use Longer

Lifetime extension

Repair No

Use Again

Repack and remanufacture

End of life manual availability [End of Life Information](#)

Take-back No

WEEE Label



The product must be disposed on European Union markets following specific waste collection and never end up in rubbish bins

Dimensions Drawings

Dimensions

Views: Front - Left - Rear

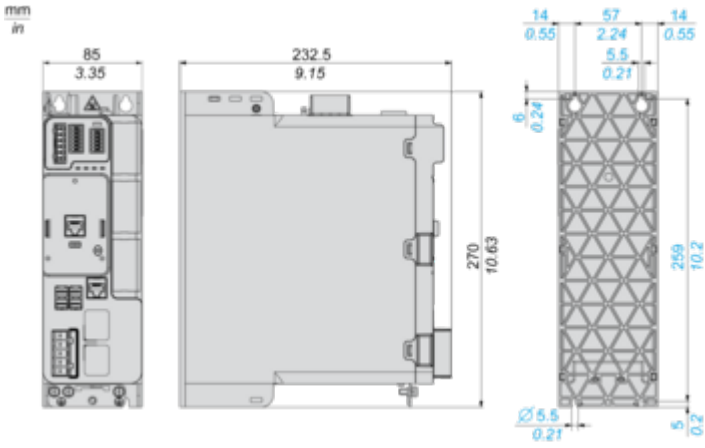

Mounting and Clearance

Clearance

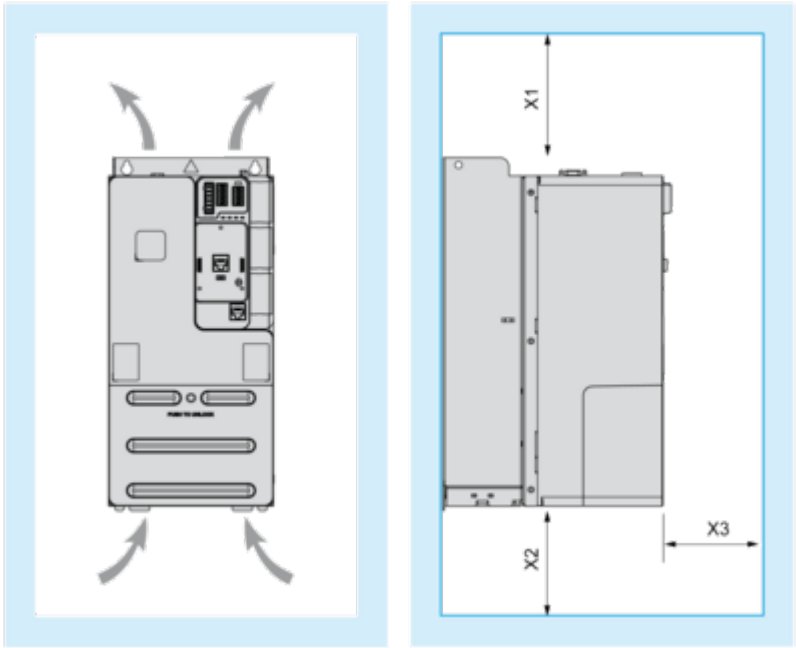

| X1 | X2 | X3 | | | |
|-------|--------|-------|--------|------|--------|
| mm | in. | mm | in. | mm | in. |
| ≥ 100 | ≥ 3.94 | ≥ 100 | ≥ 3.94 | ≥ 60 | ≥ 2.36 |

Mounting Types

Mounting Type A: Side by Side IP20

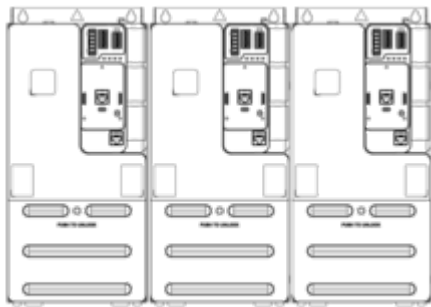

Possible, at ambient temperature $\leq 50\text{ }^{\circ}\text{C}$ (122 $^{\circ}\text{F}$)

Mounting Type B: Individual IP20



$a \geq 50\text{ mm}$ (1.97 in.) from 50...60 $^{\circ}\text{C}$, no restriction below 50 $^{\circ}\text{C}$

Connections and Schema

Connections and Schema

Three-phase Power Supply - Diagram With Line Contactor

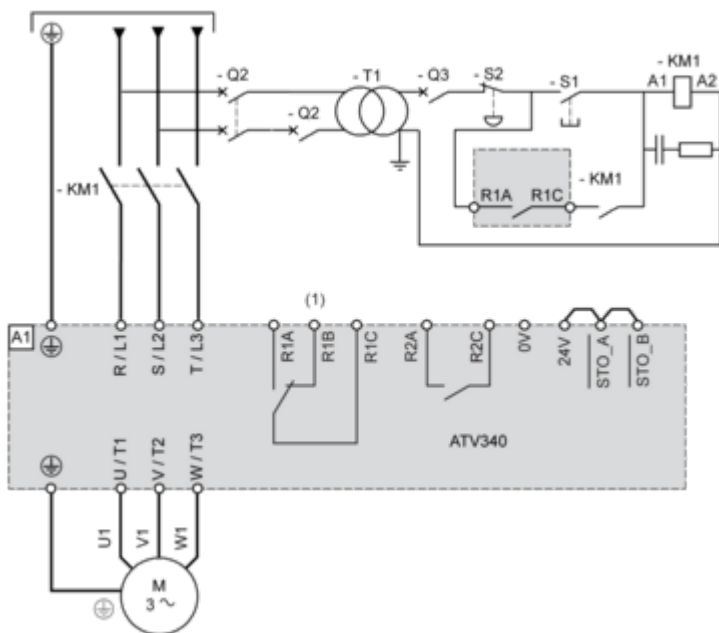

(1) : Use relay output R1 set to operating state Fault to switch Off the product once an error is detected.

NOTE :

- Press S1 until the initialization of the drive is finished.
- An external 24V power supply can be connected so that the control part of the drive is always power supplied.

Three-phase Power Supply - Diagram With Downstream Contactor

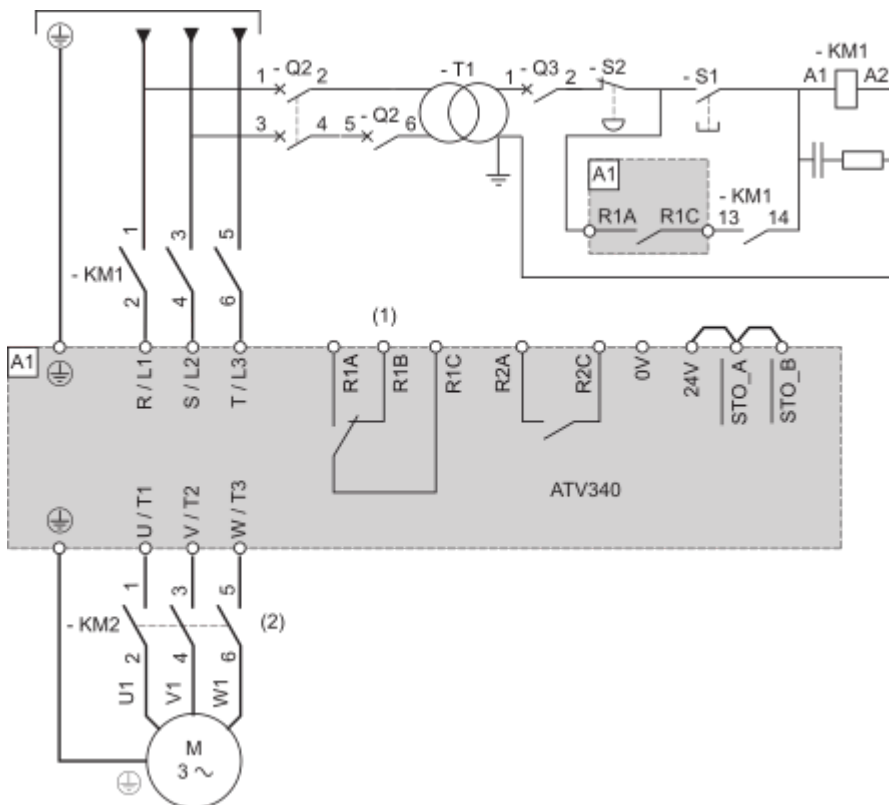

- (1) : Use relay output R1 set to operating state Fault to switch Off the product once an error is detected.
- (2) : Command of KM2 can be done by using the [Output contactor cmd] OCC function. For more information, refer to the programming manual.

NOTE :

- Close upstream contactor, then press S1 after the initialization of the drive is finished.
- An external 24V power supply can be connected so that the control part of the drive is always power supplied.

Sensor Connection

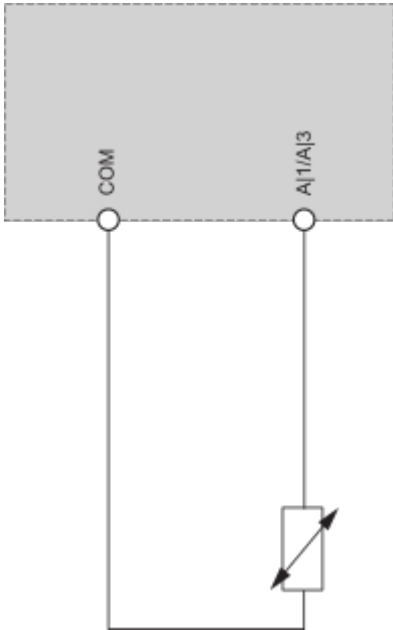

Control Block Wiring Diagram

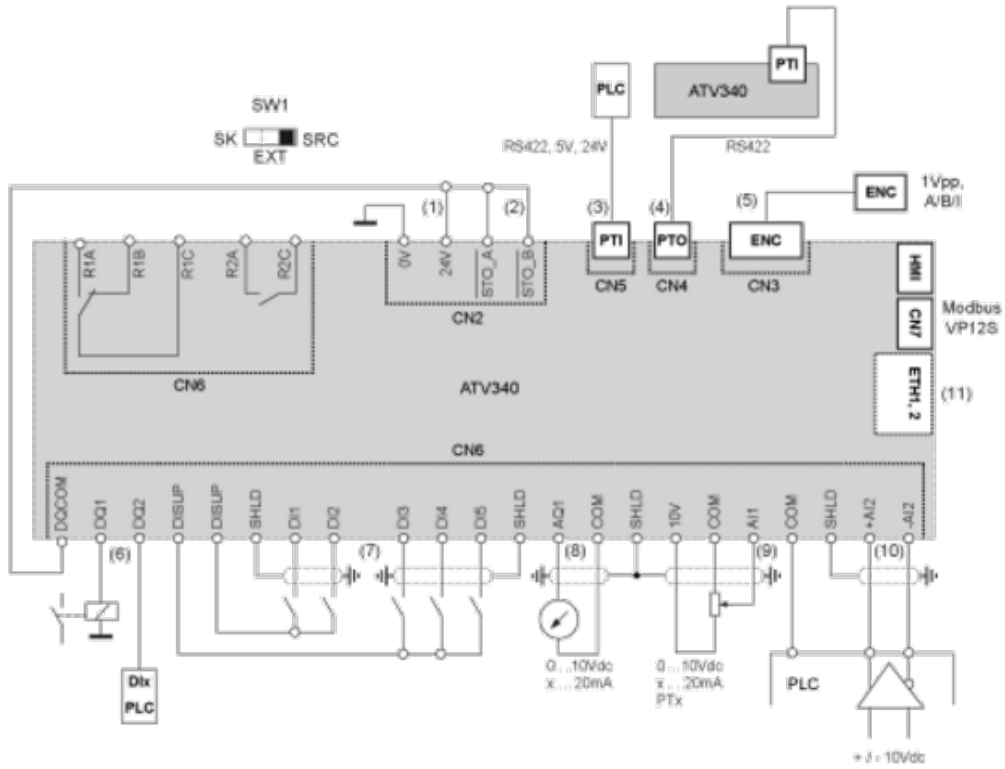

- (1) : 24V In, Out, maximum supply current 200 mA is provided,
- (2) : STO - Safe Torque Off, see ATV340 Embedded safety function manual NVE64143
- (3) : PTI - Pulse Train In, from external source (eg.PLC) Pulse - Direction or A-B signals can be connected
- (4) : PTO - Pulse Train Out, can be used to connect to a 2nd ATV340 PTI
- (5) : To connect a motor position feedback encoder
- (6) : Digital output, e.g. to connect a contactor, also usable as DI
- (7) : Digital inputs
- (8) : Analog output, e.g. to connect a meter
- (9) : Analog input, e.g. from potentiometer
- (10) : Differential analog input, e.g. as speed reference from external PLC differential, +/- 10 V
- (11) : 2 advanced Ethernet ports ETH1, ETH2 (ATV340*****E) or 2 Sercos III ports S3P1, S3P2 (ATV340*****S)

Digital Inputs Wiring

Digital Inputs: Internal Supply

Using DISUP Signal

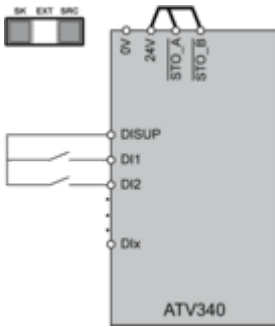

In SRC position DISUP outputs 24 V. In SK position DISUP is connected to 0 V.

Digital Inputs: External Supply

Positive Logic, Source, European Style



Negative Logic, Sink, Asian Style



Digital Inputs: Internal supply

Negative Logic, Sink, Asian Style

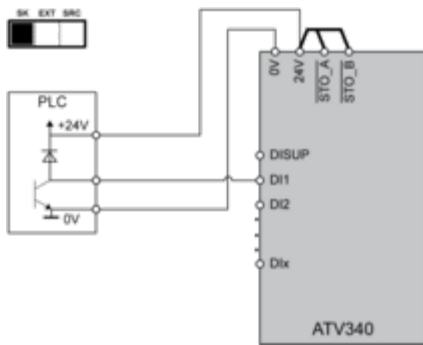

Digital Outputs Wiring

Digital Outputs: Internal Supply

Positive Logic, Source, European Style, DQCOM to +24V

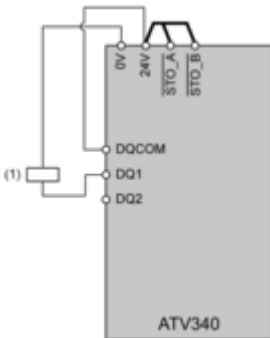

(1) Relay or valve

Negative Logic, Sink, Asian Style, DQCOM to 0V

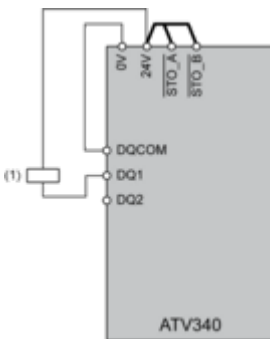

(1) Relay or valve

Digital Outputs: External Supply

Positive Logic, Source, European Style, DQCOM to +24V

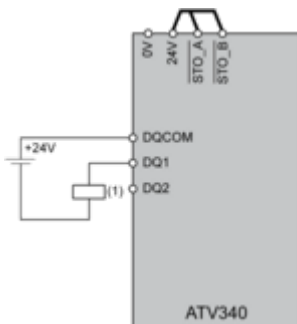

(1) Relay or valve

Negative Logic, Sink, Asian Style, DQCOM to 0V



(1) Relay or valve

Performance Curves

Derating Curves

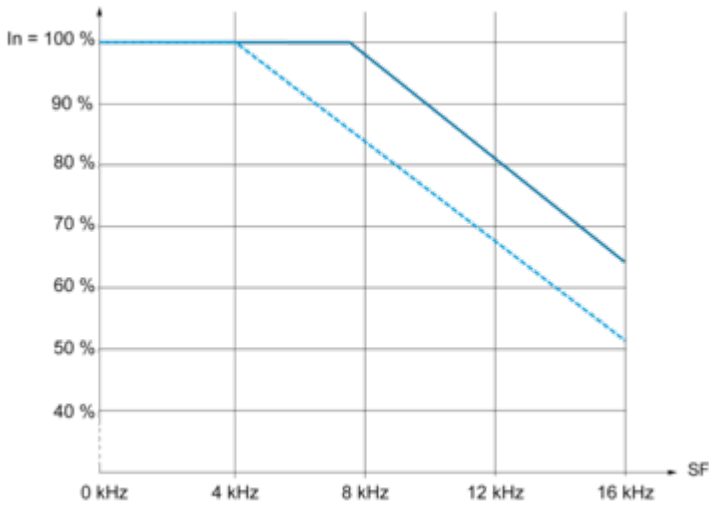

— 40 °C (104 °F) - Mounting type A and B

- - - 50 °C (122 °F) - Mounting type A and B

In : Nominal Drive Current

SF : Switching Frequency

Technical Illustration

Dimensions

