

Product datasheet

Specifications



Medium Voltage Variable Speed Drive ATV6000 - 3.3 kV - 700 kVA

ATV6000D700A3333NA3

Main

Range of product	Altivar Process ATV6000
Product or component type	Medium voltage variable speed drive
Device short name	ATV6000
Product specific application	Process and utilities
Assembly style	In floor-standing enclosure
Provided equipment	Human machine interface Phase-shifting transformer Plinth Cooling fans Enclosure Medium voltage arrestors Power cells
Colour of enclosure	Light grey (RAL 7035)
IP degree of protection	IP31 conforming to IEC 60529
Type of cooling	Forced convection
Input type	18 pulse diode rectifier bridge
Output type	IGBT inverter cells multilevel PWM
[Us] rated supply voltage	3.3 kV +/- 10 %
Supply frequency	50 Hz +/- 5 %
Network number of phases	3 phases
Prospective line I _{sc}	31.5 kA for 150 ms
Output voltage	<= power supply voltage
Permissible temporary current boost	1.2 x I _n during 60 s (normal duty) 1.5 x I _n during 3 s (normal duty) 1.5 x I _n during 60 s (heavy duty) 1.8 x I _n during 3 s (heavy duty)
Speed drive output frequency	0.1...120 Hz
Frequency resolution	0.01 Hz
Product destination	Permanent magnet motors Synchronous motors Asynchronous motors
Asynchronous motor control profile	Closed loop vector control U/F vector control Energy saving control Vector control with slip compensation in open loop
Synchronous motor control profile	Permanent magnet control in open loop Permanent magnet control in close loop Line start permanent magnet motor
Apparent power	700 kVA

Excluding VAT and subject to change. Please check with your local distributor through "Where to buy"

Maximum THDI	<3 % conforming to IEEE 519-1992
Power factor	96
Motor power kW	560 kW for normal duty 530 kW for heavy duty
Continuous output current	117 A normal duty 112 A heavy duty
Maximum transient current	176 A during 3 s (normal duty) 210 A during 3 s (heavy duty)
Line current	123 A normal duty 116 A heavy duty
Energy efficiency ratio	0.985 inverter 0.96 total drive including transformer
Power losses	24.4 kW normal duty 23.1 kW heavy duty
cable entry	Bottom
Width	2760.0 mm
Depth	1400.0 mm
Height	2641.0 mm
Net weight	3522.0 kg
Volume of cooling air	10934 m ³ /h
Noise level	80 dB
EMC filter	Integrated conforming to IEC 61800-3 category C3 control Integrated conforming to IEC 61800-3 category C4 power
Display type	10 inch LCD touch screen multi-language

Complementary

Protection type	Line supply overvoltage: drive Line supply undervoltage: drive Line supply phase loss: drive Overvoltages on the DC bus: drive Thermal overload for transformer: drive Cabinet overheating: drive Overcurrent: drive Overload: drive Short-circuit protection: drive IGBT for each cell: drive Thermal protection: motor Motor phase break: motor Motor earth fault: motor Break on the control circuit: drive Fan monitoring: drive
Option card	Slot A: communication module for Profibus DP V1 Slot A: communication module for PROFINET Slot A: communication module for DeviceNet Slot A: communication module for CANopen daisy chain RJ45 Slot A: communication module for CANopen SUB-D 9 Slot A: communication module for CANopen screw terminals Slot A: communication module for EtherCAT Slot B: 5/12 V digital encoder interface module Slot B: analog encoder interface module Slot B: resolver encoder interface module Slot B: HTL encoder interface module Slot A/slot B: digital and analog I/O extension module Slot A/slot B: output relay extension module
Connector type	2 RJ45 (on the control block) for Ethernet IP/Modbus TCP 1 RJ45 (on the control block) for Modbus serial
Communication port protocol	Modbus serial Ethernet IP/Modbus TCP

Supply	Internal supply for digital inputs and PoE 24 V DC 21...27 V, <200 mA overload and short-circuit protection Internal supply for reference potentiometer (1 to 10 kOhm) 10.5 V DC +/- 5 %, <10 mA overload and short-circuit protection External supply for digital inputs 24 V DC 19...30 V External supply for cooling fan 400 V AC +/- 10 % 3 kVA External supply for control circuit 100...240 V AC 47...63 Hz External supply for control circuit 120...370 V DC +/- 10 % 1 kVA Auxiliary power supply 230 V AC +/- 10 %
Analogue input type	configurable voltage: 0...10 V DC, impedance: 30 kOhm, resolution: 12 bits configurable current: 0...20 mA, impedance: 250 Ohm, resolution: 12 bits
Discrete input number	10
Discrete input type	DI1...DI8 programmable, 24 V DC (<= 30 V), impedance: 3.5 kOhm DI7, DI8 programmable as pulse input: 0...30 kHz, 24 V DC (<= 30 V) POEA, POEB PWM output enable, 24 V DC (<= 30 V), impedance: > 2.2 kOhm
Analogue output number	2
Analogue output type	Configurable voltage: 0...10 V DC impedance 470 Ohm, resolution 10 bits Configurable current: 0...20 mA impedance 500 Ohm, resolution 10 bits
Discrete output number	2
Discrete output type	Logic output <= 30 V DC 100 mA
Relay output number	3
Relay output type	Configurable relay logic R1: fault relay NO/NC Configurable relay logic R2: sequence relay NO Configurable relay logic R3: sequence relay NO
Isolation	Electrical between power and control
Overvoltage category	II conforming to IEC 61800-5-1 motor side III conforming to IEC 61800-5-1 line side III conforming to IEC 61800-5-1 low voltage connections

Environment

Electromagnetic compatibility	Electrostatic discharge immunity test level 3 conforming to IEC 61000-4-2 Radiated radio-frequency electromagnetic field immunity test level 3 conforming to IEC 61000-4-3 Electrical fast transient/burst immunity test level 4 conforming to IEC 61000-4-4 1.2/50 µs - 8/20 µs surge immunity test level 3 conforming to IEC 61000-4-5 Conducted radio-frequency immunity test level 3 conforming to IEC 61000-4-6
Pollution degree	2 conforming to IEC 61800-5-1
Environmental characteristic	3K3 conforming to IEC 60721-3-3 3B1 conforming to IEC 60721-3-3 3C2 conforming to IEC 60721-3-3 3S1 conforming to IEC 60721-3-3 3M1 conforming to IEC 60721-3-3
Relative humidity	5...95 % without condensation conforming to IEC 60068-2-3
Ambient air temperature for operation	0...40 °C 40...50 °C with derating factor -25...70 °C during transport
Ambient air temperature for storage	0...50 °C
Operating altitude	<= 1000 m without derating 1000...2000 m with derating factor
Standards	IEC 61800-3 EN/IEC 61800-4 IEC 61800-5-1 IEC 60529 IEEE 519:1992 EN/IEC 60076
Marking	EAC CE

Contractual warranty

Warranty (in months)

18



Environmental Data

Schneider Electric aims to achieve Net Zero status by 2050 through supply chain partnerships, lower impact materials, and circularity via our ongoing “Use Better, Use Longer, Use Again” campaign to extend product lifetimes and recyclability.

[Environmental Data explained >](#)

[How we assess product sustainability >](#)

Use Longer



Lifetime extension

Repair

No

Product datasheet **ATV6000D700A3333NA3**

Dimensions Drawings

Dimensions

Product datasheet ATV600D700A3333NA3

mm
in.

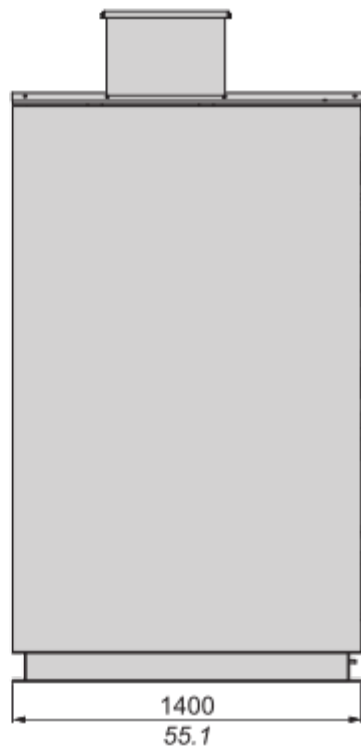
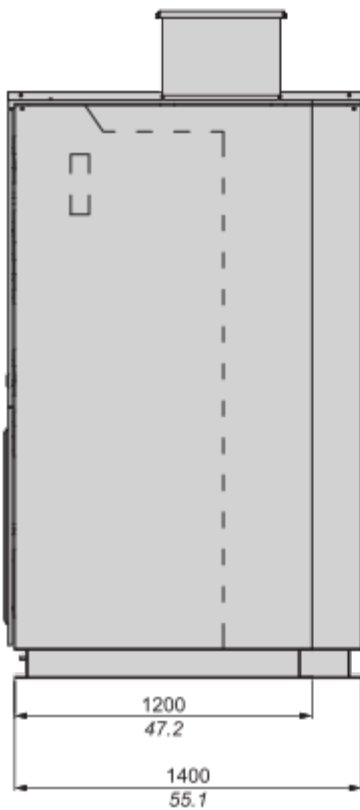
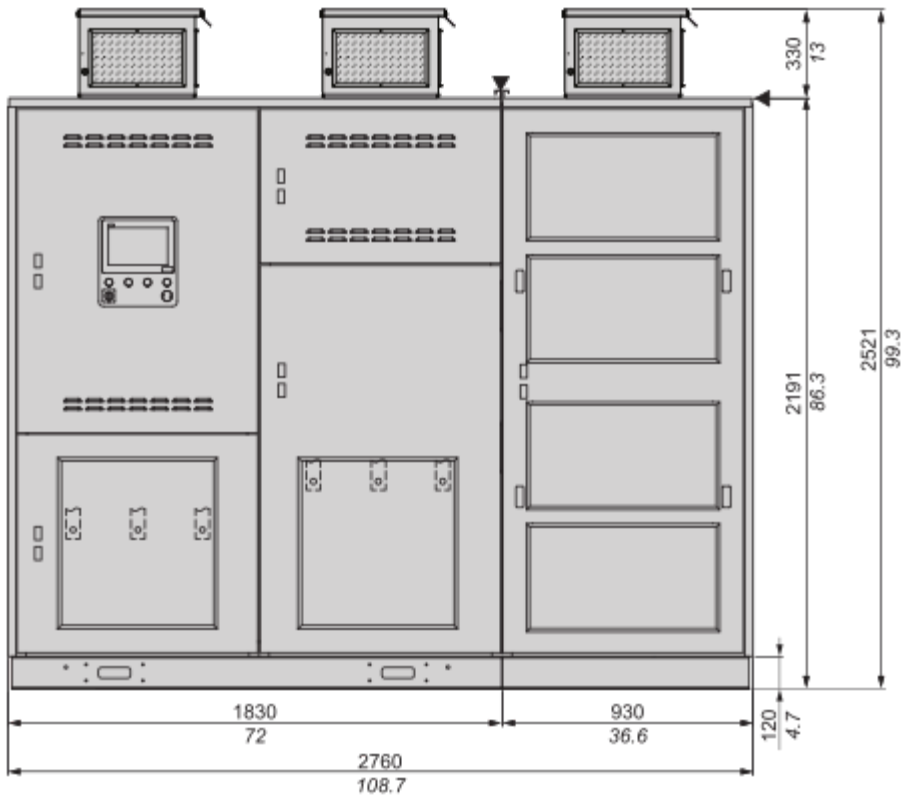

Connections and Schema

Wiring Diagram

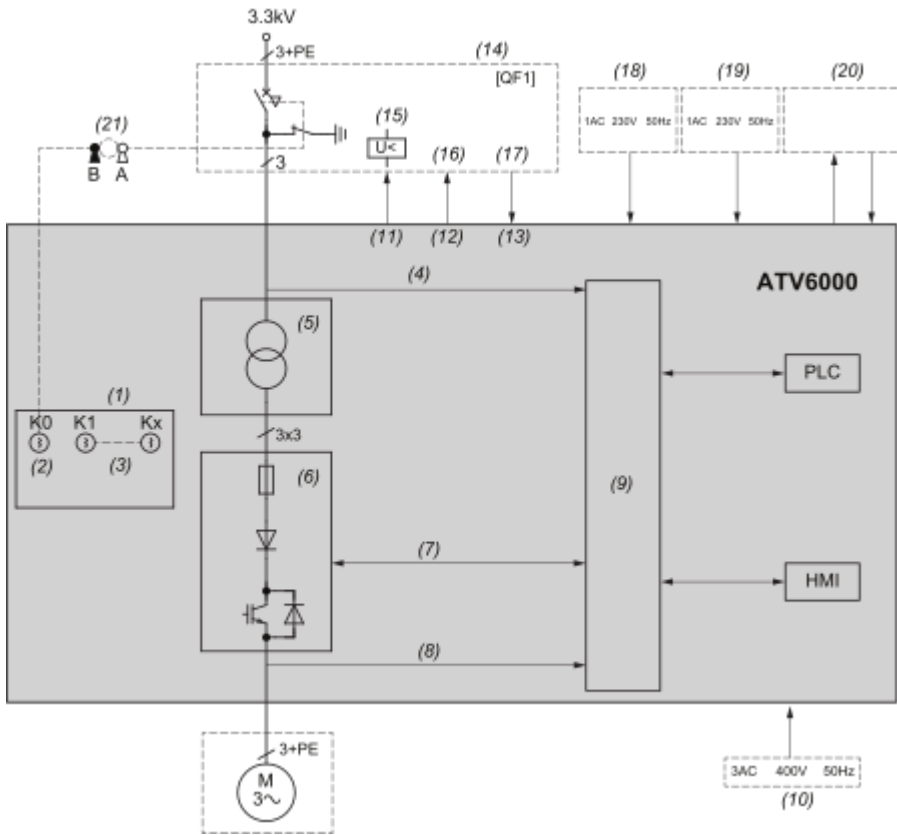

- (1) : Key Box
- (2) : Free Key
- (3) : Captive Keys
- (4) : Voltage & Current Measurement
- (5) : Transformer
- (6) : Inverter (3 module per phase)
- (7) : Fibre Optic
- (8) : Voltage & Current Measurement
- (9) : Master Controller
- (10) : Fan Power Supply 12kVA
- (11) : MCB to trip
- (12) : MCB Enable to close
- (13) : MCB Status Feedback
- (14) : Circuit Breaker
- (15) : Under-voltage coil
- (16) : Enable to close
- (17) : Status Feedback From MCB (Open /Closed)
- (18) : Auxiliary Supply 4kVA
- (19) : Secured Supply 1kVA
- (20) : Control signals
- (21) : Free key and CB key must be bonded together

Product datasheet ATV600D700A3333NA3

Technical Illustration

Dimensions

