

Product datasheet

Specifications



soft starter for asynchronous motor - ATS01 - 25 A - 110..480V - 2.2..11 KW

ATS01N125FT

Price: 7,739.40 ZAR

Main

Range of product	Altistart 01
Product destination	Asynchronous motors
Product or component type	Soft starter
Product specific application	Simple machine
Device short name	ATS01
Network number of phases	1 phase
[Us] rated supply voltage	110...480 V - 10...10 %
Motor power kW	11 kW, 3 phases at 400 V 3 kW, 3 phases at 230 V 4 kW, 3 phases at 230 V 9 kW, 3 phases at 400 V 7.5 kW, 3 phases at 400 V 5.5 kW, 3 phases at 230 V 2.2 kW, 1 phase at 230 V
Motor power hp	11 hp, 3 phases at 460 V 2 hp, 3 phases at 210 V 3 hp, 3 phases at 210 V 5 hp, 3 phases at 230 V 9 hp, 3 phases at 460 V 7.5 hp, 3 phases at 230 V
IcL starter rating	25 A
Utilisation category	AC-53B conforming to EN/IEC 60947-4-2
Current consumption	125 A at nominal load
Type of start	Start with voltage ramp
Power dissipation in W	1 W at full load and at end of starting 126 W in transient state

Complementary

Assembly style	With heat sink
Function available	Integrated bypass
Supply voltage limits	99...528 V
Supply frequency	50...60 Hz - 5...5 %
Network frequency	47.5...63 Hz
Output voltage	<= power supply voltage
[Uc] control circuit voltage	110 V AC +/- 10 % at 35 mA 24 V AC/DC +/- 10 % at 30 mA 240 V AC +/- 10 % at 80 mA

Excluding VAT and subject to change. Please check with your local distributor through "Where to buy"

Starting time	1 s / 100 5 s / 20 Adjustable from 1 to 5 s
Starting torque	30...80 % of starting torque of motor connected directly on the line supply
Discrete output current	2 A DC-13 3 A AC-15
tightening torque	0.5 N.m 1.9...2.5 N.m
Electrical connection	4 mm screw clamp terminal - rigid 1 1...10 mm ² AWG 8 power circuit Screw connector - rigid without cable end 1 0.5...2.5 mm ² AWG 14 control circuit 4 mm screw clamp terminal - rigid 2 1...6 mm ² AWG 10 power circuit Screw connector - rigid 2 0.5...1 mm ² AWG 17 control circuit Screw connector - flexible with cable end 1 0.5...1.5 mm ² AWG 16 control circuit 4 mm screw clamp terminal - flexible without cable end 1 1.5...10 mm ² AWG 8 power circuit Screw connector - flexible without cable end 1 0.5...2.5 mm ² AWG 14 control circuit 4 mm screw clamp terminal - flexible with cable end 2 1...6 mm ² AWG 10 power circuit 4 mm screw clamp terminal - flexible without cable end 2 1.5...6 mm ² AWG 10 power circuit Screw connector - flexible without cable end 2 0.5...1.5 mm ² AWG 16 control circuit
Marking	CE
Operating position	Vertical +/- 10 degree
Height	124 mm
Width	45 mm
Depth	131 mm
Net weight	0.35 kg
Compatibility code	ATS01N1
Power range	2.2...3 kW at 200...240 V 3 phases 2.2...3 kW at 200...240 V 1 phase 4...6 kW at 200...240 V 3 phases 7...11 kW at 200...240 V 3 phases 7...11 kW at 380...440 V 3 phases
Motor starter type	Soft starter

Environment

Electromagnetic compatibility	Conducted and radiated emissions level B conforming to CISPR 11 Conducted and radiated emissions level B conforming to IEC 60947-4-2 Damped oscillating waves level 3 conforming to IEC 61000-4-12 Electrostatic discharge level 3 conforming to IEC 61000-4-2 EMC immunity level 3 conforming to EN 50082-1 EMC immunity level B conforming to EN 50082-2 Harmonics level 3 conforming to IEC 1000-3-2 Harmonics level 3 conforming to IEC 1000-3-4 Immunity to conducted interference caused by radio-electrical fields level 3 conforming to IEC 61000-4-6 Immunity to electrical transients level 4 conforming to IEC 61000-4-4 Immunity to radiated radio-electrical interference level 3 conforming to IEC 61000-4-3 Micro-cuts and voltage fluctuation conforming to IEC 61000-4-11 Voltage/current impulse level 3 conforming to IEC 61000-4-5
Standards	EN/IEC 60947-4-2
Product certifications	C-Tick CCC GOST CSA UL
IP degree of protection	IP20
Pollution degree	2 conforming to EN/IEC 60947-4-2
Vibration resistance	1 gn (f= 13...150 Hz) conforming to EN/IEC 60068-2-6 1.5 mm peak to peak (f= 3...13 Hz) conforming to EN/IEC 60068-2-6

Shock resistance	15 gn for 11 ms conforming to EN/IEC 60068-2-27
Relative humidity	5...95 % without condensation or dripping water conforming to EN/IEC 60068-2-3
Ambient air temperature for operation	-10...40 °C (without derating) 40...50 °C (with current derating of 2 % per °C)
Ambient air temperature for storage	-25...70 °C conforming to EN/IEC 60947-4-2
Operating altitude	<= 1000 m without derating > 1000 m with current derating of 2.2 % per additional 100 m

Packing Units

Unit Type of Package 1	PCE
Number of Units in Package 1	1
Package 1 Height	5.200 cm
Package 1 Width	15.500 cm
Package 1 Length	17.500 cm
Package 1 Weight	407.000 g
Unit Type of Package 2	S03
Number of Units in Package 2	14
Package 2 Height	30.000 cm
Package 2 Width	30.000 cm
Package 2 Length	40.000 cm
Package 2 Weight	6.333 kg

Contractual warranty

Warranty (in months)	18
-----------------------------	----



Environmental Data

Schneider Electric aims to achieve Net Zero status by 2050 through supply chain partnerships, lower impact materials, and circularity via our ongoing “Use Better, Use Longer, Use Again” campaign to extend product lifetimes and recyclability.

[Environmental Data explained >](#)

[How we assess product sustainability >](#)

Use Better



Materials and Substances

Packaging made with recycled cardboard

Yes

Packaging without single use plastic

Yes

[EU RoHS Directive](#)

Pro-active compliance (Product out of EU RoHS legal scope)

REACH Regulation

[REACH Declaration](#)

Use Longer



Lifetime extension

Repair

No

Use Again



Repack and remanufacture

Take-back

No

WEEE Label



The product must be disposed on European Union markets following specific waste collection and never end up in rubbish bins

Dimensions Drawings

Dimensions

Mounting on Symetrical (35 mm) Rail

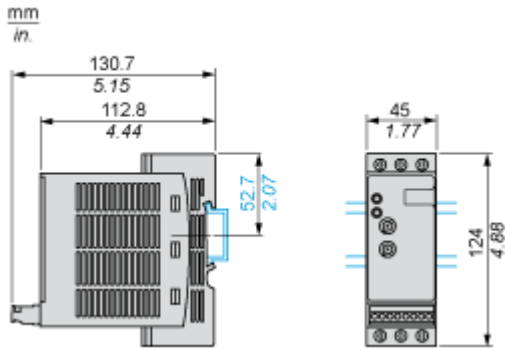

Screw Fixing

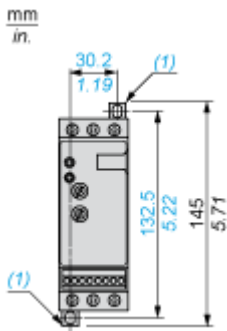

(1) Retractable fixings

Connections and Schema

Example of 3-phase Power Supply Connection

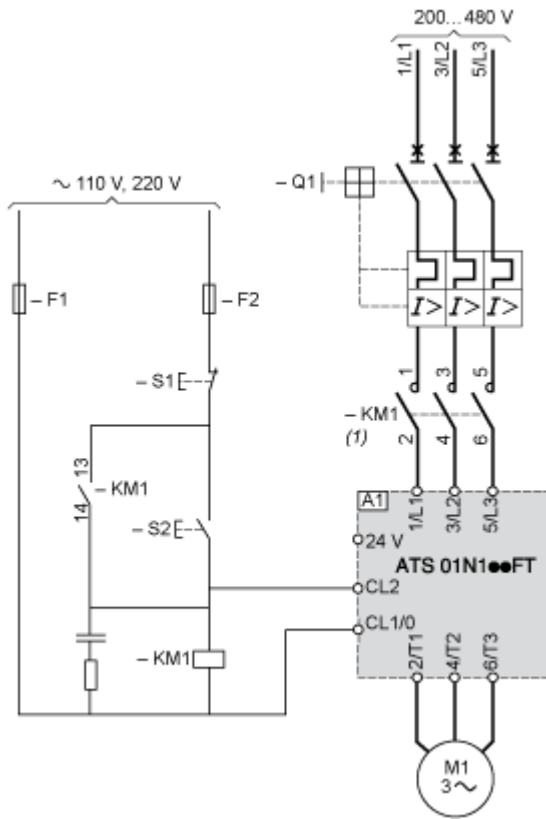

(1) A line contactor must be used in the sequence.

A1 : Soft starter

Q1 : Motor circuit-breaker

KM1 : Contactors

F1, F2 : Control protection fuses

S1, S2 : Pushbuttons

Technical Description

Function Diagram

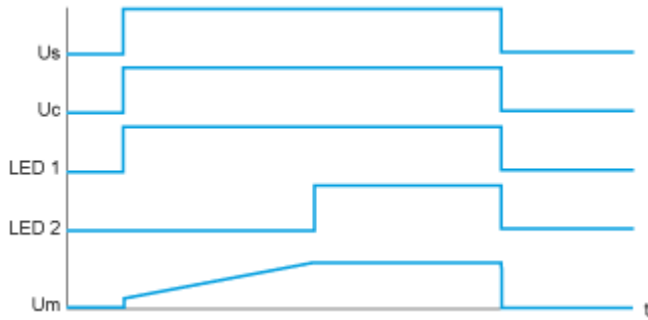

- Us : Power supply voltage
- Uc : Control supply voltage
- LED 1 : Green LED
- LED 2 : Yellow LED
- Um : Motor voltage